

## Kuličkové matice FSU

- Přírubové matice FSU pro válcované kuličkové šrouby
- Průměry 16 - 80 mm
- Jednoduché, pravý závit

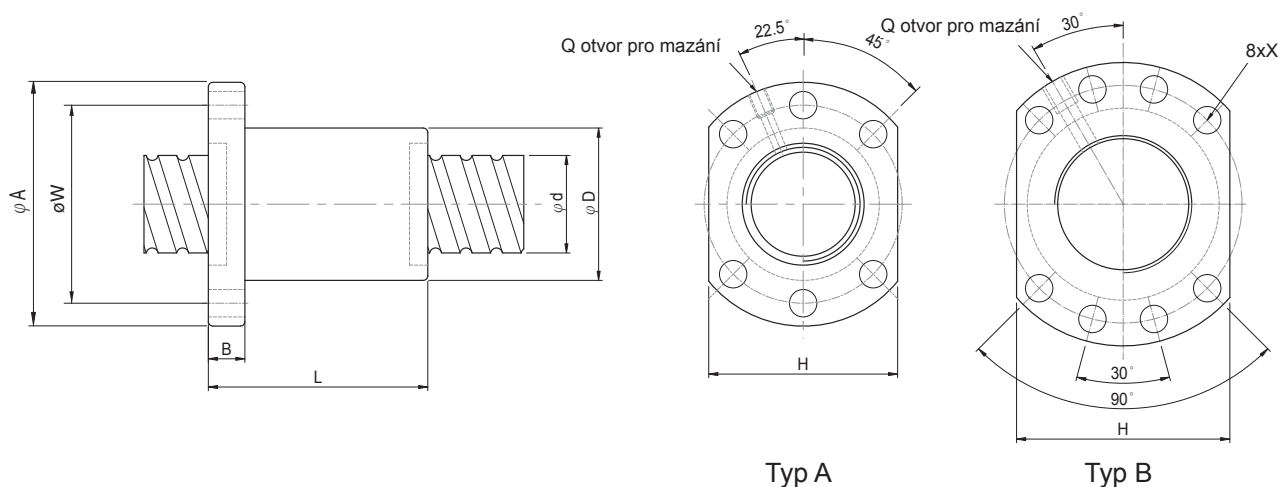

Objednací číslo	Šroub d	Stoupání l	Kuličky Da	D mm	A mm	B mm	L mm	W mm	X mm	Typ	H	Q	n	Únosnost N	
														Dynamická	Statická
KM-1605-4-FSU	16	5	3,175	28,0	48,0	10	50,0	38	5,5	A	40	M6	4	7800	17900
KM-1610-3-FSU	16	10	3,175	28,0	48,0	12	65,0	38	5,5	A	40	M6	3	7160	12320
KM-2005-4-FSU	20	5	3,175	36,0	58,0	10	53,0	47	6,6	A	44	M6	4	11000	22800
KM-2505-4-FSU	25	5	3,175	40,0	62,0	10	53,0	51	6,6	A	48	M6	4	12500	30700
KM-2510-4-FSU	25	10	4,762	40,0	62,0	12	85,0	51	6,6	A	48	M6	4	19440	38770
KM-3205-4-FSU	32	5	3,175	50,0	80,0	12	53,0	65	9,0	A	62	M6	4	14000	40800
KM-3210-3-FSU	32	10	6,350	50,0	80,0	16	77,5	65	9,0	A	62	M6	3	26050	53100
KM-3210-4-FSU	32	10	6,350	50,0	80,0	16	90,0	65	9,0	A	62	M6	4	33900	71700
KM-4005-4-FSU	40	5	3,175	63,0	93,0	16	56,0	78	9,0	B	70	M8	4	15750	52900
KM-4010-4-FSU	40	10	6,350	63,0	93,0	18	93,0	78	9,0	B	70	M8	4	38500	94700
KM-5010-4-FSU	50	10	6,350	75,0	110,0	18	93,0	93	11,0	B	85	M8	4	43900	124000
KM-6310-4-FSU	63	10	6,350	90,0	125,0	18	98,0	108	11,0	B	95	M8	4	50700	166000
KM-8010-4-FSU	80	10	6,350	105,0	145,0	20	98,0	125	13,5	B	110	M8	4	56200	213000

Kuličkový šroub - příklad pro objednání:

KS1605-1000    KS    = kuličkový šroub  
                   1605    = průměr 16 mm a stoupání 5 mm  
                   1000    = délka šroubu v mm