

Typ MF_B - s otvory pro ukotvení

- Talíř: Polyamid, tvrzený
- Šroub: Ocel, pozink
- Tlumící pryž: Pryž NBR, olejovzdorná
- Se dvěma otvory pro ukotvení (předchystané)
- Tlumící pryž je nutné objednat zvlášť

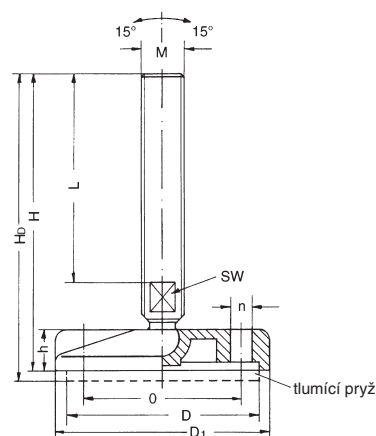

| Objednací číslo | | M | D | D ₁ | H | h | H _D | L | SW | n | O | Zatížení N | Hmotnost kg | |
|-----------------|---------|-----|----|----------------|-----|----|----------------|-----|----|----|----|------------|-------------|-------|
| Podstavec | Pryž | | | | | | | | | | | | Podstavec | Pryž |
| MF 8.80B | MF D80 | M8 | 70 | 80 | 65 | 16 | 67 | 40 | 12 | 9 | 54 | 9.000 | 0,052 | 0,028 |
| MF 10.80B | MF D80 | M10 | 70 | 80 | 95 | 16 | 97 | 71 | 12 | 9 | 54 | 9.000 | 0,062 | 0,028 |
| MF 12.80B | MF D80 | M12 | 70 | 80 | 95 | 16 | 97 | 69 | 12 | 9 | 54 | 9.000 | 0,094 | 0,028 |
| MF 14.80B | MF D80 | M14 | 70 | 80 | 85 | 16 | 87 | 56 | 11 | 9 | 54 | 10.000 | 0,130 | 0,028 |
| MF 16.80B | MF D80 | M16 | 70 | 80 | 90 | 16 | 92 | 61 | 13 | 9 | 54 | 10.000 | 0,158 | 0,028 |
| MF 20.80B | MF D80 | M20 | 70 | 80 | 130 | 16 | 132 | 100 | 19 | 9 | 54 | 10.000 | 0,280 | 0,028 |
| MF 24.100B | MF D100 | M24 | 92 | 102 | 185 | 19 | 188 | 146 | 22 | 11 | 74 | 12.000 | 0,596 | 0,048 |

Typ MF SS - nerezové

- Talíř: Nerezová ocel 1.4301
- Šroub: Nerezová ocel 1.4305
- Tlumící pryž: Pryž NBR, olejovzdorná
- Matice: Šestihranná DIN 934, nerezová ocel

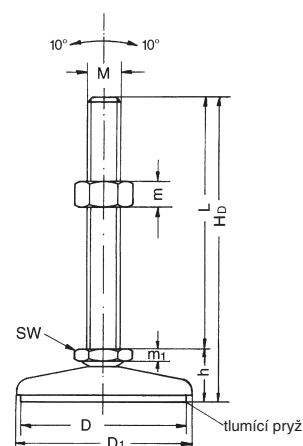

| Objednací číslo | M | D | D ₁ | h | H _D | L | m | m ₁ | SW | Zatížení N | Hmotnost kg |
|-----------------|-----|----|----------------|----|----------------|-----|------|----------------|----|------------|-------------|
| MF 8.40 SS | M8 | 37 | 40 | 13 | 73 | 60 | 6,5 | 2,6 | 13 | 2.000 | 0,066 |
| MF 10.60 SS | M10 | 57 | 60 | 18 | 88 | 70 | 8,0 | 3,2 | 17 | 3.000 | 0,184 |
| MF 12.60 SS | M12 | 57 | 60 | 18 | 95 | 80 | 10,0 | 3,7 | 19 | 4.000 | 0,226 |
| MF 14.80 SS | M14 | 75 | 80 | 26 | 126 | 100 | 11,0 | 4,4 | 22 | 10.000 | 0,472 |
| MF 16.80 SS | M16 | 75 | 80 | 26 | 146 | 120 | 13,0 | 5,0 | 24 | 15.000 | 0,530 |
| MF 20.100 SS | M20 | 95 | 100 | 30 | 180 | 150 | 16,0 | 6,5 | 30 | 20.000 | 0,924 |
| MF 24.100 SS | M24 | 95 | 100 | 30 | 210 | 180 | 18,0 | 7,5 | 36 | 25.000 | 1,250 |